



Tightening automation.
Only excellent solutions.

Air nutrunner motors

- Tightening torque control system:
with air shut-off, with slip clutch,
without clutch (stall type)
- Tightening torque: from 0,4 up to 40 Nm

Fiam®

PEOPLE AND SOLUTIONS

Tightening automation

Requirements change, efficiency remains.

Accurate, reliable, compact and performing: these are Fiam **air nutrunner motors**. The ideal solution for many applications in different production fields. Specifically designed and manufactured for **industrial automation**, they are used in single or multi-spindle, manual or fixtured tightening units. Nutrunners can be installed in automatic assembly lines, in rotary-table machines, on multi-spindle tightening units, on fastening slides, anthropomorphic robots. They are suitable for **every type of joint**. Extremely robust, they guarantee constant performances in the long run also when used in heavy duty conditions.



The right solution for every need.

Needs aren't the same for everyone, therefore everybody should be able to get customized solutions. **Different torque control systems are available and can be chosen** depending on application and type of joint and fastener.

AIR NUTRUNNER MOTORS WITH AIR SHUT-OFF

PAGE 6

Thanks to the automatic and immediate air shut-off device, these motors guarantee **high torque repeatability**. Ideal to assemble components manufactured with high quality materials (for example in assembly of car components). They can be equipped with built-in torque transducer: besides verifying whether the clutch correctly works, it reads the torque the nutrunner delivered and allows data collection: as a consequence the tightening cycle is checked and possible errors identified (partially tightened screws, already tightened screws, crossed thread, etc.).

AIR NUTRUNNER MOTORS WITH SLIP CLUTCH

PAGE 8

Extremely versatile, their torque control device with slip clutch is suitable for **assembly of several types of materials**.

AIR NUTRUNNER MOTORS WITHOUT CLUTCH

PAGE 10

A type of motors that, thanks to direct and continuous torque drive, guarantees tightening evenness **also in presence of extremely soft joints** (e.g. assembly of steel components with interposed rubber seals of significant thickness). Upon request they can be equipped with built-in torque transducer that allows torque value measurement. Datas are collected, the tightening cycle is checked and possible errors identified (partially tightened screws, already tightened screws, crossed thread, etc.).

Electronic nutrunner motors.

Fiam also manufactures a **range of brushless electronic nutrunner motors with computerized control**, that can be used on different types of joint. These solutions are necessary when you have to control, monitor and constantly verify the entire assembly process including the memorization of the tightening datas. They are ideal when it is indispensable to assure the **certified quality of final products**.

For further information about these high technology solutions see 'MCB: high technology electronic nutrunner motors' (n. 71) or contact Fiam Technical Consultancy Service.



Be demanding

Reliability

A careful design guarantees long lifetime and reliability of the components which results in high productivity, reduced maintenance and repair costs

Fiam air nutrunner motors aren't standard screwdrivers adjusted to be installed on a machine, instead they are **solutions specifically and accurately designed to be used in the industrial automation field.**

Their main **features** to be used in automation applications are:

- **robust thrust bearings** to stand up to the fast and continuous thrusts of the fastening slides as often happens in the automatic production cycles.
- **ideal external geometries** for fixtured application.
- **safe unlocking bushes**: to avoid the accidental loss of the accessory during the heavy production cycles.
- **practical pre-arrangement to convey exhaust** in order to reduce noise level and use oil separator filters.
- **ported signal**, to interface with line PLC.

Made in Fiam: designed and manufactured by Fiam they guarantee **reliable operation in every working condition**

High resistance: they are manufactured with sturdy and reliable materials

High performances: the reduction gear system guarantees maximum output, long lifetime of the kinematic chain and reduced noise level.

Maximum reliability both in vertical and in horizontal axis in respect to components to be tightened

20MC

MOTRIX: newly conceived air motor ensures high performances and maximum torque **also at low air feed pressure.**

TRACS2: the innovative torque control system ensures a very **high torque repeatability**, i.e. a very low Mean Shift value also in the presence of variability of the joint softness level.

This system maintains same torque values for hundreds of thousands of cycles.

Don't be satisfied with the maximum

Productivity

Considerable increase of the efficiency of the production cycle thanks to innovative systems

Reduced weight and dimensions: they can be easily installed on machine also with reduced room available

Axial compensator: an accessory to eliminate any difference of screw height on the component, to facilitate entry of screw and reduce axial thrust on the motor's mechanical components protecting the internal components and guaranteeing their long life.

For models without clutch, it is possible to **easily adjust** the torque, speed and direction by using simple control methods.

Air shut-off nutrunner motors permit to control the tightening cycle through a **pneumatic signal** that, interfaced with PLC of machine management, can supply end cycle signals, torque achievement and start the up/down movement of the supporting frames and other cycle sequences. The pneumatic signal can be picked up by appropriate threaded hole of the nutrunner motors.



Perfection is
in your hands

Naturally
innovative

Ergonomics Ecology

Enhancement of tool performances in regard to ergonomics and operator's safety

Innovative systems designed paying even more attention to the environment and its safeguard

Available in **reversible and non reversible versions**. Reversible motors are provided with two entrances for compressed air that permit alternatively the input and the output of the compressed air.



Models with air shut-off can be also manufactured with clutch for **left tightenings control**.

Available **low revolutions nutrunners**: suitable for different applications and with critical joints.

Customized solutions in respect to type of joint and application.

Reduced noise level: the effective silencing systems guarantee a reduced noise level caused by air exhaust in compliance with International standards. Moreover the accurate study of inner kinematic motions permits to **reduce** considerably **mechanical noise too**.

No risk of overheating also in heavy duty conditions (repetitive use, repetitive stops/starts or change of directions) the performances are unchanged.

Extremely reduced weights and dimensions: they favour the installation on machines that can be easily used also by operators (e.g. tightening multispindle units).

The advanced technological design permits **considerable decrease of compressed air consumption**, without affecting tool performance.

The inner kinematic motions optimize efficiency and transmit the available power with **minimum dispersions**.

20MC

TRACS2: the torque control system allows high running speed which, together with the push-to-start system, reduces working time and compressed air consumption.

Nutrunners design allows use of separator filters for conveying the air exhaust and in order to **eliminate the emission of oil fog into working environment**.

All the components are **easy to dispose of** since built using recyclable materials.

Eco-friendly packaging.

20MC

Innovative design principles guarantee a higher rotating speed of the new air motor at the same tightening torque, with evident reduction of tightening cycle time.

TRACS2: the clutch accuracy reduces to a minimum level the need of quality control at the end of the assembly process, with a remarkable increase of productivity.

New accessory drive with quick change chuck: it favours easier and safer accessory replacement (the spring load effectively prevent incidental bit unlocking).

There are two types of starting system:

Push to start: is a simple and economical system for only right-hand rotation motors. The motor starts automatically when a push of about 2 or 3 Kg is applied directly to it. This is the recommended system for starting motors installed on automatic fastening slides.

Direct start from a remote control signal is achieved by the application of a 3-way pneumatic control valve (on right hand rotation motors), or 5-way control valve (on reversible motors). Direct start is recommended for multispindle assembly systems where the operator's effort has to be reduced.



Nutrunner motors with air shut-off

Type of motor		Tightening torque on soft joint		Idle speed	Starting system	Reversibility	Weight		Dimensions	Air consumption	Accessories	Noise level*
Model	Code	Min. / Max. Nm	Min. / Max. in lb				Kg	lb				
20MC2A	112314706	0,6 ÷ 2,5	5.31 - 22.125	2700	↓	↻	0,750	1.65	page 12	5,5	⊕ F1/4"	75
20MC3A	112314707	0,4 ÷ 3	3.54 - 26.55	1400	↓	↻	0,770	1.69	page 12	5,5	⊕ F1/4"	75
20MC4A	112314708	0,4 ÷ 4	3.54 - 35.4	1000	↓	↻	0,770	1.69	page 12	5,5	⊕ F1/4"	75
20MC5A	112314709	0,4 ÷ 5	3.54 - 44.25	650	↓	↻	0,770	1.69	page 12	5,5	⊕ F1/4"	75
20MC5A-250	112307260	0,4 ÷ 5	3.54 - 44.25	250	↓	↻	0,850	1.87	page 12	5,5	⊕ F1/4"	75
MCSEZ4A	114613734	0,9 ÷ 4	7.965 - 35.4	2500	↓	↻	0,930	2.05	page 13	9	⊕ F1/4"	76
MCSE5A	114613735	2,5 ÷ 5	22.125 - 44.25	1500	↓	↻	0,980	2.16	page 13	9	⊕ F1/4"	76
MCSE8A	114613738	2,5 ÷ 8	22.125 - 70.8	1000	↓	↻	0,980	2.16	page 13	9	⊕ F1/4"	76
MCSE10A	114613740	2,5 ÷ 10	22.125 - 88.5	500	↓	↻	0,980	2.16	page 13	9	⊕ F1/4"	76
MCY9A	116313709	7 ÷ 18	61.95 - 159.3	800	↓	↻	1,500	3.3	page 14	10	⊕ F1/4"	79
MCY11A	116313711	7 ÷ 24	61.95 - 212.4	550	↓	↻	1,500	3.3	page 14	10	⊕ F1/4"	79
MCG25A1	114609198	12 ÷ 25	106.2 - 221.25	600	↓	↻	2,200	4.84	page 15	13	⊖ M3/8"	79
MCG40A1	114609199	18 ÷ 40	159.3 - 354	450	↓	↻	2,200	4.84	page 13	13	⊖ M3/8"	79
20MCS2A	112314226	0,6 ÷ 2,5	5.31 - 22.125	2700	↓↕	↻	0,750	1.65	page 12	5,5	⊕ F1/4"	75
20MCS3A	112314227	0,4 ÷ 3	3.54 - 26.55	1400	↓↕	↻	0,770	1.69	page 12	5,5	⊕ F1/4"	75
20MCS4A	112314228	0,4 ÷ 4	3.54 - 35.4	1000	↓↕	↻	0,770	1.69	page 12	5,5	⊕ F1/4"	75
20MCS5A	112314229	0,4 ÷ 5	3.54 - 44.25	650	↓↕	↻	0,770	1.69	page 12	5,5	⊕ F1/4"	75
MSCSEZ4A	114613234	0,9 ÷ 4	7.965 - 35.4	2500	↓↕	↻	0,910	2.00	page 13	9	⊕ F1/4"	76
MSCSE5A	114613235	2,5 ÷ 5	22.125 - 44.25	1500	↓↕	↻	0,990	2.18	page 13	9	⊕ F1/4"	76
MSCSE8A	114613238	2,5 ÷ 8	22.125 - 70.8	1000	↓↕	↻	0,990	2.18	page 13	9	⊕ F1/4"	76
MSCSE10A	114613240	2,5 ÷ 10	22.125 - 88.5	500	↓↕	↻	0,990	2.18	page 13	9	⊕ F1/4"	76
MSCY9A	116313209	7 ÷ 18	61.95 - 159.3	800	↓↕	↻	1,500	3.3	page 14	10	⊕ F1/4"	79
MSCY11A	116313211	7 ÷ 24	61.95 - 212.4	550	↓↕	↻	1,500	3.3	page 14	10	⊕ F1/4"	79
20MC2RA	112514716	0,6 ÷ 2,5	5.31 - 22.125	2700	↓	↻	0,760	1.67	page 12	5,5	⊕ F1/4"	77
20MC3RA	112514717	0,4 ÷ 3	3.54 - 26.55	1400	↓	↻	0,780	1.72	page 12	5,5	⊕ F1/4"	77
20MC4RA	112514718	0,4 ÷ 4	3.54 - 35.4	1000	↓	↻	0,780	1.72	page 12	5,5	⊕ F1/4"	77
20MC5RA	112514719	0,4 ÷ 5	3.54 - 44.25	650	↓	↻	0,780	1.72	page 12	5,5	⊕ F1/4"	77
20MC5RA-250	112507021	0,4 ÷ 5	3.54 - 44.25	250	↓	↻	0,860	1.87	page 12	5,5	⊕ F1/4"	77
MCSEZ4RA	114813734	0,9 ÷ 4	7.965 - 35.4	2500	↓	↻	0,940	2.07	page 13	9	⊕ F1/4"	78
MCSE5RA	114813735	2,5 ÷ 5	22.125 - 44.25	1500	↓	↻	0,990	2.18	page 13	9	⊕ F1/4"	78
MCSE8RA	114813738	2,5 ÷ 8	22.125 - 70.8	1000	↓	↻	0,990	2.18	page 13	9	⊕ F1/4"	78
MCSE10RA	114813740	2,5 ÷ 10	22.125 - 88.5	500	↓	↻	0,990	2.18	page 13	9	⊕ F1/4"	78
MCY9RA	116513709	7 ÷ 16	61.95 - 141.6	700	↓	↻	1,500	3.3	page 14	10	⊕ F1/4"	81
MCY11RA	116513711	7 ÷ 24	61.95 - 212.4	450	↓	↻	1,500	3.3	page 14	10	⊕ F1/4"	81
MCG25RA1	114807206	12 ÷ 25	106.2 - 221.25	600	↓	↻	2,200	4.84	page 14	13	⊖ M3/8"	81
MCG40RA1	114807308	18 ÷ 40	159.3 - 354	450	↓	↻	2,300	5.06	page 14	13	⊖ M3/8"	81

Nutranner motors with automatic air shut-off with built-in axial compensator

Type of motor		Tightening torque on soft joint		Idle speed	Starting system	Reversibility	Weight	Dimensions	Air consumption	Accessories	Noise level*	
Model	Code	Min. Nm	Max. in lb									Min. r.p.m.
MCG25A1-TEL	114609196	12 ÷ 25	106.2 - 221.25	650	↓	↻	2,450	5.39	page 15	13	<input type="checkbox"/> M3/8"	79
MCG40A1-TEL	114609200	18 ÷ 40	159.3 - 354	450	↓	↻	2,450	5.39	page 15	13	<input type="checkbox"/> M3/8"	79
MCG25RA1-TEL	114807293	12 ÷ 25	106.2 - 221.25	600	↓	↻	2,450	5.39	page 15	13	<input type="checkbox"/> M3/8"	81
MCG40RA1-TEL	114807294	18 ÷ 40	159.3 - 354	450	↓	↻	2,450	5.39	page 15	13	<input type="checkbox"/> M3/8"	81

Legend

↻ Screw rotation clockwise

↻ **Reversibility:** The models are suitable for tightening and untightening operations

↓ **Direct start**

⇓ **Push-to-start**

- * Noise level has been measured in accordance with ISO 3744 and ISO 15744.
- * Additional factor: 3dBA spread in method and production (ISO 15744).
- * Noise level has been indicated as guide for machine manufacturer that install these motors.
- * The figures shown are measured at a pressure of 6,3 bar (in accordance with ISO 2787), the recommended operating pressure.
- * Tightening torque values have been measured in accordance with ISO 5393 standard.
- * Accessory drive: 1/4" 6,35 mm female hexagonal drive (ISO 1173); male square drive (ISO 1174-2).
- * The code number must be used when ordering.
- * For installation instructions see 'Use and maintenance manual'.

Torque values are to be considered purely indicative and may be influenced by the softness of the type of joint, the type and length of the screw, the pressure and quantity of the feeding air, etc. In order to ensure the best performances and long life of air nutrunner motors, in particularly harsh work conditions (high number of cycles per minute and/or high torque values), we advise adjusting torque level not higher than 80% of maximum torque stated in the performances chart. For all further details, please apply to Fiam Technical Consultancy Service.

Chart of torque range obtainable with clutch springs assembled on the tool or supplied with

Model	Assembled on the tool – grey colour - Ø wire 3,2 mm code 595103202		Supplied with – black colour - Ø wire 2,2 mm code 595102204	
	Torque range on soft joint Nm	in lb	Torque range on soft joint Nm	in lb
20MC2A / 20MCS2A	0,8 ÷ 2,5	7.08 - 22.125	0,6 ÷ 1,2	5.31 - 10.62
20MC3A / 20MCS3A	0,8 ÷ 3	7.08 - 26.55	0,4 ÷ 1,2	3.54 - 10.62
20MC4A / 20MCS4A	0,8 ÷ 4	7.08 - 35.4	0,4 ÷ 1,2	3.54 - 10.62
20MC5A / 20MCS5A	0,8 ÷ 5	7.08 - 44.25	0,4 ÷ 1,2	3.54 - 10.62

Model	Air inlet	Recommended hose bore
20MC...A, 20MCS...A, 20MC...RA	1/8" gas	Ø 5 mm
MCSE...A, MSCSE...A, MCSE...RA	1/4" gas	Ø 8 mm
MCY...A, MSCY...A, MCY...RA	1/4" gas	Ø 8 mm
MCG...A1, MCG...RA1	1/4" gas	Ø 8 mm
MCG...A1-TEL, MCG...RA1-TEL	1/4" gas	Ø 8 mm

Standard equipment (supplied with the motor)

- Clutch adjustment key
- Supplementary clutch spring (only for 20MC... models)
- Use and maintenance manual
- Eco-friendly packaging

Accessories available upon request

- Bits, sockets, conveyors and other compressed air system accessories: (see Accessories catalogue)
- Accessories for automation (see on page 21)
- Axial compensators and flange brackets (see on page 19)

Models available upon request

- Models with quick change chuck
- Models with modified flange and/or with customized body design
- Models with axial compensator
- Models with different speeds than the ones indicated on the chart
- Models with special clutch for left tightening control
- Models with Offset device







OFFSET DEVICE

 Fiam air nutrunner motors are designed for use with lubricated compressed air

Nutrrunner motors with slip clutch

Type of motor		Tightening torque on soft joint		Idle speed	Starting system	Reversibility	Weight		Dimensions	Air consumption	Accessories	Axial compensator output
Model	Code	Min. Nm	Max. in lb				Min. r.p.m.	Max. Kg				
MCZE2	112311722	0,8 ÷ 2,5	708 - 22.125	2800	↓	↻	0,660	1.45	page 16	7	⊕ F 1/4"	□ 1/4"
MCZE3	112311723	0,8 ÷ 3	708 - 26.55	1300	↓	↻	0,750	1.65	page 16	7	⊕ F 1/4"	□ 1/4"
MCZE4	112311724	0,8 ÷ 3,3	708 - 29.205	850	↓	↻	0,750	1.65	page 16	7	⊕ F 1/4"	□ 1/4"
MCZE5	112311725	0,6 ÷ 4,2	5.31 - 37.17	600	↓	↻	0,750	1.65	page 16	7	⊕ F 1/4"	□ 1/4"
MCSE4	114611714	1 ÷ 5,8	8.85 - 51.33	2500	↓	↻	0,840	1.85	page 17	9	⊕ F 1/4"	□ 3/8"
MCSE5	114611715	1,5 ÷ 7,5	13.275 - 66.375	1500	↓	↻	0,850	1.87	page 17	9	⊕ F 1/4"	□ 3/8"
MCSE8	114611718	1,5 ÷ 9,5	13.275 - 84.075	1000	↓	↻	0,850	1.87	page 17	9	⊕ F 1/4"	□ 3/8"
MCSE10	114611720	1,5 ÷ 12	13.275 - 106.2	500	↓	↻	0,850	1.87	page 17	9	⊕ F 1/4"	□ 3/8"
MCY7-1	116311701	4,6 ÷ 13	40.71 - 115.05	1700	↓	↻	1,100	2.42	page 18	10	⊕ F 1/4"	□ 3/8"
MCY9-1	116311702	6 ÷ 16	53.1 - 141.6	750	↓	↻	1,300	2.86	page 18	10	⊕ F 1/4"	□ 3/8"
MCY11-1	116311703	6 ÷ 22	53.1 - 194.7	500	↓	↻	1,300	2.86	page 18	10	⊕ F 1/4"	□ 3/8"
MSCZE2	112311222	0,8 ÷ 2,5	708 - 22.125	2800	↓ ↓	↻	0,720	1.58	page 16	7	⊕ F 1/4"	□ 1/4"
MSCZE3	112311223	0,8 ÷ 3	708 - 26.55	1300	↓ ↓	↻	0,730	1.61	page 16	7	⊕ F 1/4"	□ 1/4"
MSCZE4	112311224	0,8 ÷ 3,3	708 - 29.205	850	↓ ↓	↻	0,730	1.61	page 16	7	⊕ F 1/4"	□ 1/4"
MSCZE5	112311225	0,6 ÷ 4,2	5.31 - 37.17	600	↓ ↓	↻	0,730	1.61	page 16	7	⊕ F 1/4"	□ 1/4"
MSCSE4	114611214	1 ÷ 5,8	8.85 - 51.33	2500	↓ ↓	↻	0,910	2.00	page 17	9	⊕ F 1/4"	□ 3/8"
MSCSE5	114611215	1,5 ÷ 7,5	13.275 - 66.375	1500	↓ ↓	↻	0,920	2.02	page 17	9	⊕ F 1/4"	□ 3/8"
MSCSE8	114611218	1,5 ÷ 9,5	13.275 - 84.075	1000	↓ ↓	↻	0,920	2.02	page 17	9	⊕ F 1/4"	□ 3/8"
MSCSE10	114611220	1,5 ÷ 12	13.275 - 106.2	500	↓ ↓	↻	0,920	2.02	page 17	9	⊕ F 1/4"	□ 3/8"
MCZE2R	112511722	0,8 ÷ 2,5	708 - 22.125	2800	↓	↻	0,790	1.74	page 16	7	⊕ F 1/4"	□ 1/4"
MCZE3R	112511723	0,8 ÷ 3	708 - 26.55	1300	↓	↻	0,800	1.76	page 16	7	⊕ F 1/4"	□ 1/4"
MCZE4R	112511724	0,8 ÷ 3,3	708 - 29.205	850	↓	↻	0,800	1.76	page 16	7	⊕ F 1/4"	□ 1/4"
MCZE5R	112511725	0,6 ÷ 4,2	5.31 - 37.17	600	↓	↻	0,800	1.76	page 16	7	⊕ F 1/4"	□ 1/4"
MCSE4R	114811714	1 ÷ 5,8	8.85 - 51.33	2500	↓	↻	0,780	1.72	page 17	9	⊕ F 1/4"	□ 3/8"
MCSE5R	114811715	1,5 ÷ 7,5	13.275 - 66.375	1500	↓	↻	0,870	1.91	page 17	9	⊕ F 1/4"	□ 3/8"
MCSE8R	114811718	1,5 ÷ 9,5	13.275 - 84.075	1000	↓	↻	0,870	1.91	page 17	9	⊕ F 1/4"	□ 3/8"
MCSE10R	114811720	1,5 ÷ 12	13.275 - 106.2	500	↓	↻	0,870	1.91	page 17	9	⊕ F 1/4"	□ 3/8"
MCY7R-1	116511701	4,5 ÷ 13	39.825 - 115.05	1600	↓	↻	1,100	2.42	page 18	10	⊕ F 1/4"	□ 3/8"
MCY9R-1	116511702	6 ÷ 16	53.1 - 141.6	700	↓	↻	1,300	2.86	page 18	10	⊕ F 1/4"	□ 3/8"
MCY11R 1	116511703	6 ÷ 22	53.1 - 194.7	450	↓	↻	1,300	2.86	page 18	10	⊕ F 1/4"	□ 3/8"

Legend

-  Screw rotation clockwise
-  **Reversibility:** The models are suitable for tightening and untightening operations
-  **Direct start**
-  **Push-to-start**

- The figures shown are measured at a pressure of 6,3 bar (in accordance with ISO 2787), the recommended operating pressure.
- The tightening torque values have been measured in accordance with ISO 5393 standard.
- Accessory drive: 1/4", 6,35 mm female hexagonal drive (ISO 1173) male square drive (ISO 1174-2).
- The code number must be used when ordering.
- For installation instructions see 'Use and maintenance manual'.

Torque values are to be considered purely indicative and may be influenced by the softness of the type of joint, the type and length of the screw, the pressure and quantity of the feeding air, etc. In order to ensure the best performances and long life of air nutrunner motors, in particularly harsh work conditions (high number of cycles per minute and/or high torque values), we advise adjusting torque level not higher than 80% of maximum torque stated in the performances chart. For all further details, please apply to Fiam Technical Consultancy Service.

Chart of torque range obtainable with clutch springs assembled on the tool or supplied with

Model	Torque range on soft joint Nm in lb	Torque range on soft joint Nm in lb	Torque range on soft joint Nm in lb	Torque range on soft joint Nm in lb
	<i>Assembled on the tool</i> Brown colour - Ø wire 1,6 mm Code 595201600	<i>Supplied with</i> Pink colour - Ø wire 2 mm Code 595202000	<i>Supplied with</i> Silver colour - Ø wire 2,1 mm Code 595202100	<i>Supplied with</i> Gold colour - Ø wire 2,2 mm Code 595202200
MCZE2	0,8 ÷ 2,5 7.08 - 22.125			
MCZE3	0,8 ÷ 2,2 7.08 - 19.47	1,8 ÷ 3 15.93 - 26.55		
MCZE4	0,8 ÷ 2,5 7.08 - 22.125		2 ÷ 3,3 17.7 - 29.205	
MCZE5	0,6 ÷ 1,9 5.31 - 16.815			1 ÷ 4,2 8.85 - 31.17
	<i>Assembled on the tool</i> White colour - Ø wire 1,6 mm Code 595102502	<i>Supplied with</i> Light-blue colour - Ø wire 1,5 mm Code 595101509	<i>Supplied with</i> Pink colour - Ø wire 2 mm Code 595102006	<i>Supplied with</i> Red colour - Ø wire 3,5 mm Code 595103504
MCSE4	3 ÷ 5,8 26.55 - 51.33	1 ÷ 3,2 8.85 - 28.32		
MCSE5	3 ÷ 7,5 26.55 - 66.375		1,5 ÷ 4,5 13.275 - 39.825	
MCSE8	1,5 ÷ 4,5 13.275 - 39.825			3,5 ÷ 9,5 30.975 - 84.075
MCSE10	1,5 ÷ 4,5 13.275 - 39.825			3,5 ÷ 12 30.975 - 106.2
	<i>Assembled on the tool</i> Brown colour - Ø wire 1,6 mm Code 595201600	<i>Supplied with</i> Pink colour - Ø wire 2 mm Code 595202000	<i>Supplied with</i> Silver colour - Ø wire 2,1 mm Code 595202100 7.08 - 22.125	<i>Supplied with</i> Gold colour - Ø wire 2,2 mm Code 595202200
MSCZE2	0,8 ÷ 2,5 7.08 - 22.125			
MSCZE3	0,8 ÷ 2,2 7.08 - 19.47	1,8 ÷ 3 15.93 - 26.55		
MSCZE4	0,8 ÷ 2,5 7.08 - 22.125		2 ÷ 3,3 17.7 - 29.205	
MSCZE5	0,6 ÷ 1,9 5.31 - 16.815			1 ÷ 4,2 8.85 - 31.17
	<i>Assembled on the tool</i> White colour - Ø wire 1,6 mm Code 595102502	<i>Supplied with</i> Light-blue colour - Ø wire 1,5 mm Code 595101509	<i>Supplied with</i> Pink colour - Ø wire 2 mm Code 595102006	<i>Supplied with</i> Red colour - Ø wire 3,5 mm Code 595103504
MSCSE4	3 ÷ 5,8 26.55 - 51.33	1 ÷ 3,2 8.85 - 28.32		
MSCSE5	3 ÷ 7,5 26.55 - 66.375		1,5 ÷ 4,5 13.275 - 39.825	
MSCSE8	1,5 ÷ 4,5 13.275 - 39.825			3,5 ÷ 9,5 30.975 - 84.075
MSCSE10	1,5 ÷ 4,5 13.275 - 39.825			3,5 ÷ 12 30.975 - 106.2
	<i>Assembled on the tool</i> Brown colour - Ø wire 1,6 mm Code 595201600	<i>Supplied with</i> Pink colour - Ø wire 2 mm Code 595202000	<i>Supplied with</i> Silver colour - Ø wire 2,1 mm Code 595202100	<i>Supplied with</i> Gold colour - Ø wire 2,2 mm Code 595202200
MCZE2R	0,8 ÷ 2,5 7.08 - 22.125			
MCZE3R	0,8 ÷ 2,2 7.08 - 19.47	1,8 ÷ 3 15.93 - 26.55		
MCZE4R	0,8 ÷ 2,5 7.08 - 22.125		2 ÷ 3,3 17.7 - 29.205	
MCZE5R	0,6 ÷ 1,9 5.31 - 16.815			1 ÷ 4,2 8.85 - 31.17
	<i>Assembled on the tool</i> White colour - Ø wire 1,6 mm Code 595102502	<i>Supplied with</i> Light-blue colour - Ø wire 1,5 mm Code 595101509	<i>Supplied with</i> Pink colour - Ø wire 2 mm Code 595102006	<i>Supplied with</i> Red colour - Ø wire 3,5 mm Code 595103504
MCSE4R	3 ÷ 5,8 26.55 - 51.33	1 ÷ 3,2 8.85 - 28.32		
MCSE5R	3 ÷ 7,5 26.55 - 66.375		1,5 ÷ 4,5 13.275 - 39.825	
MCSE8R	1,5 ÷ 4,5 13.275 - 39.825			3,5 ÷ 9,5 30.975 - 84.075
MCSE10R	1,5 ÷ 4,5 13.275 - 39.825			3,5 ÷ 12 30.975 - 106.2

Model	Air inlet	Recommended hose bore
MCZE..., MCZE...R, MCSZE...	1/8" gas	Ø 5 mm
MCSE..., MCSE...R, MSCSE, MCY...-1, MCY...R-1	1/4" gas	Ø 8 mm

Standard equipment (supplied with the motor)	Accessories available upon request	Models available upon request
<ul style="list-style-type: none"> Clutch adjustment key Supplementary clutch spring (except for MCY... models) Use and maintenance manual Eco-friendly packaging 	<ul style="list-style-type: none"> Bits, sockets, conveyors and other compressed air system accessories: (see Accessories catalogue) Accessories for automation (see on page 21) Axial compensators and flange bracket (see on page 19) 	<ul style="list-style-type: none"> Models with quick change chuck Models with modified flange and/or with customized casing Models with axial compensator Models with different speeds than the ones indicated on the chart

 Fiam air nutrunner motors are designed for use with lubricated compressed air

Nutrunner motors without clutch

These motors without clutch guarantee tightening evenness also in presence of extremely soft joints and maximum versatility: in fact **adjusting air feeding pressure leads to different torque, speed and motor power values**. Available in two versions, reversible and non-reversible, they can have different output shafts.

Type of motor		Tightening torque on soft joint		Idle speed	Reversibility	Type of output available		
Model	Code	Min / Max	Min / Max			Square	Telescopic square	Telescopic with quick release chuck*
Model	Code	Nm	in lb	r.p.m.	Type			
20MC	upon request	2,5 ÷ 10	22.125 - 88.5	600 ÷ 2600		x	x	x
28MC	upon request	4,5 ÷ 20	39.825 - 177	560 ÷ 2650		x	x	x
MNC	upon request	5 ÷ 45	44.25 - 398,25	320 ÷ 2700		x	x	x
MOC	upon request	18 ÷ 90	159.3 - 796.5	400 ÷ 2800		x	x	
20MC.R	upon request	2,5 ÷ 10	22.125 - 88.5	580 ÷ 2500		x	x	x
28MC.R	upon request	4,5 ÷ 20	39.825 - 177	395 ÷ 2350		x	x	x
MNC.R	upon request	5 ÷ 45	44.25 - 398,25	280 ÷ 2500		x	x	x
MOC.R	upon request	15 ÷ 90	159.3 - 796.5	320 ÷ 2200		x	x	

Legend



Screw rotation clockwise



Reversibility: The models are suitable for tightening and untightening operations

- The figures shown are measured at a pressure of 6,3 bar (ISO 2787), the recommended operating pressure.
- Accessory drive: 1/4", *6,35 mm female hexagonal drive (ISO 1173).
- The code number must be used when ordering.
- For installation instructions see 'Use and maintenance manual'.
- Dimensions are available upon request.

Torque values are to be considered purely indicative and may be influenced by the softness of the type of joint, the type and length of the screw, the pressure and quantity of the feeding air, etc. In order to ensure the best performances and long life of air nutrunner motors, in particularly harsh work conditions (high number of cycles per minute and/or high torque values), we advise adjusting torque level not higher than 80% of maximum torque stated in the performances chart. For all further details, please apply to **Fiam Technical Consultancy Service**.

Standard equipment (supplied with the motor)

- Use and maintenance manual
- Eco-friendly packaging

Accessories available upon request

- Bits, sockets, conveyors and other compressed air system accessories: (see Accessories catalogue)
- Accessories for automation (see on page 21)
- Axial compensators and flange bracket (see on page 19)

Models available upon request

- Models with different speeds than the ones indicated on the chart
- Models for higher torques than the ones indicated on the chart
- Models with quick change chuck (only for 20-28 MC)
- Models with special flange and/or with Customized body design



Fiam air nutrunner motors are designed for use with lubricated compressed air

How to get different values of power, torque and speed.

Performances of nutrunner motors without clutch can be modified with continuity by means of a pressure or throttling regulator that reduces or increases the air quantity in the motor.

Consequently there is a decrease or an increase of the power, torque and speed values according to ratios shown in chart 1.

There are two methods to adjust performances of nutrunner motors without clutch:

- Installing the **air flow governor** on the air inlet coupling, **stall torque is controlled**.
- installing **air flow governor** on air exhaust coupling **starting torque is maintained and motor's speed is adjusted**.

Chart 1

Ratios of variation of the performances parameters of an air motor depending on air pressure.

Pressure (bar)	Power	Torque	Speed	Consumption
7	1,21	1,17	1,03	1,15
6	1,00	1,00	1,00	1,00
5	0,77	0,83	0,95	0,82
4	0,55	0,67	0,87	0,65
3	0,37	0,50	0,74	0,47

If for instance we choose a 28MC nutrunner motor that at 6,3 bar has the performances indicated on chart, at a in-line pressure of 5 bar with reference to ratios of the chart below illustrated the parameters of this motor will be:

Motor	Bar	Potenza watt	Speed at point of maximum power – r.p.m.	Stall torque Nm
28MC120D	6	280	535	8
Motor	Bar	Potenza watt	Speed at point of maximum power – r.p.m.	Stall torque Nm
28MC120D	5	215,7	508	6,6

Power: 0,77 (coefficient) x 280 (power of motor) = 215,7 Watt (the power at 5 bar decreases)

Speed: 0,95 (coefficient) x 535 (r.p.m. of motor) = 508 (the r.p.m. at 5 bar decreases)

Maximum torque: 0,83 (coefficient) x 8 (torque of motor) = 6,6 (at 5 bar the torque value decreases)

For further information please contact Fiam Technical Consultancy Service.

Air feed and its consumption.

Air consumption of the air motor is at **maximum** when the motor turns at **idle speed**.

To obtain the performances on catalogue it is necessary to guarantee a **correct air feeding** and air exhaust and to **follow these indications**:

- Always respect **recommended air hose bore** for air feed and exhaust hoses.
- It is advisable that the **diameter of the exhaust hose** is greater than that of air supply hose. In the case of reversible motor, two inlets have to permit alternatively the entrance and the exhaust of the air i.e. that the inlet which is not used is left free so that the exhaust air can flow.
- **Avoid joints and quick couplings**; they can cause air leakage thus reducing the air flow.
- It is always advisable to use a FRL group (filter, pressure regulator, lubricator) appropriate to motor consumption.
- It is advisable to connect the exhaust hoses to **oil separator filter with built-in silencing system** that **further reduces the noise** level and **lubricates the motor** with no emission of air exhaust in working environment, allowing oil to be collected and reused.

Pneumatic circuit scheme (feed - control of the motor)

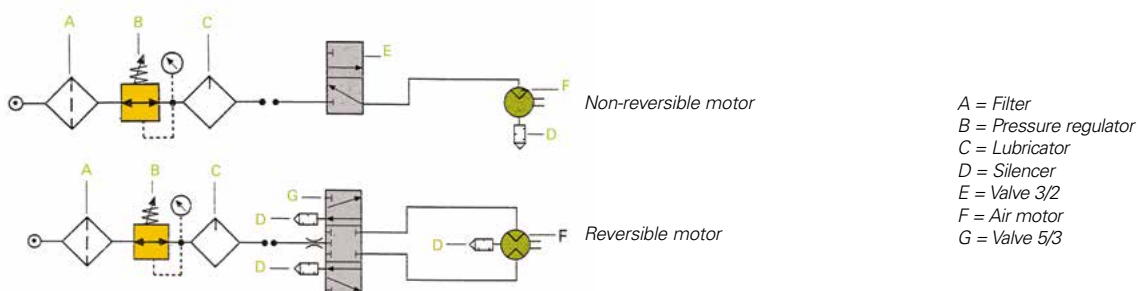

Dimensions

Nutranner motors with air shut-off

20MC...A/20MC...RA/20MCS...A/20MC5...-250 MODELS

Models	A mm	B mm	C mm
20 MC...A / 20 MC...RA	52,8	239	65
20 MCS...A	54,8	241	65
20 MC5...-250	52,8	251	77

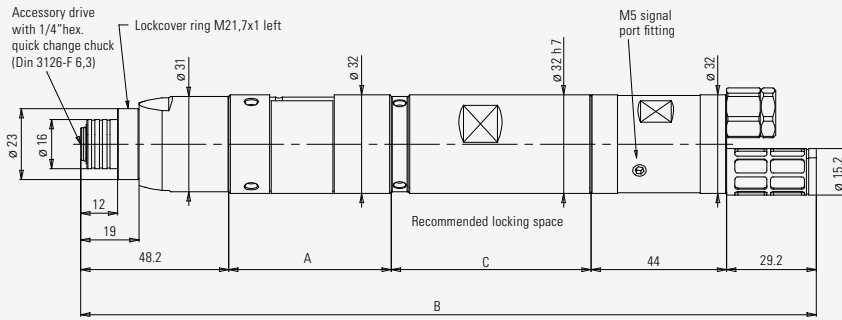

Air exhaust silencer 20MC...A / 20MCS...A

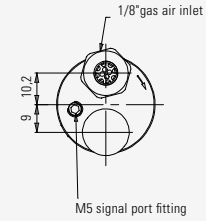

Air exhaust silencer 20MC...RA

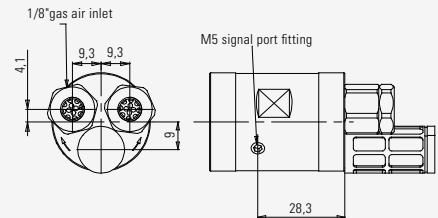

20MC...A/20MC...RA/20MCS...A/20MC5...-250 MODELS WITH AXIAL COMPENSATOR

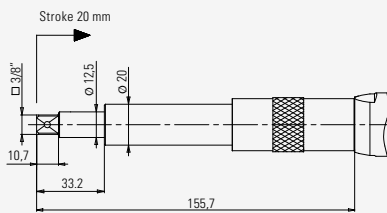

3/8" square drive axial compensator (Din 3121-F 10) (cod.680601070)

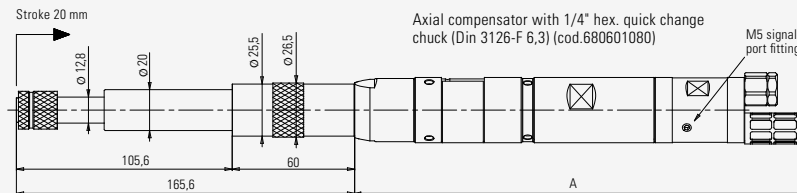

Axial compensator with 1/4" hex. quick change chuck (Din 3126-F 6,3) (cod.680601080)

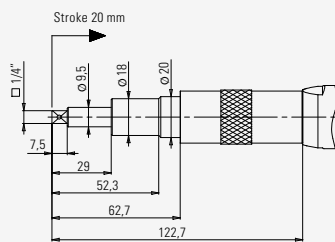

1/4" square drive axial compensator (Din 3121-F 6,3) (cod.680601090)

Models	A mm
20 MC...A / 20 MC...RA	220
20 MCS...A	222
20 MC5...-250	232

Air exhaust silencer 20MC...A / 20MCS...A

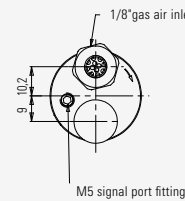

Air exhaust silencer 20MC...RA

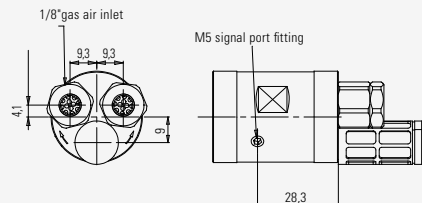

Dimensions

Nutrunner motors with air shut-off

**MCSEZ...A/MCSEZ...RA,
MCSE...A/MCSE...RA,
MSCSEZ...A,
MSCSE...A MODELS**

Models	A mm	B mm	Ø C mm
MCSEZ...A / MCSEZ...RA	259	50,5	27
MCSE...A / MCSE...RA	266	57,5	32
MSCSEZ...A	261	52,5	27
MSCSE...A	270	62,5	32

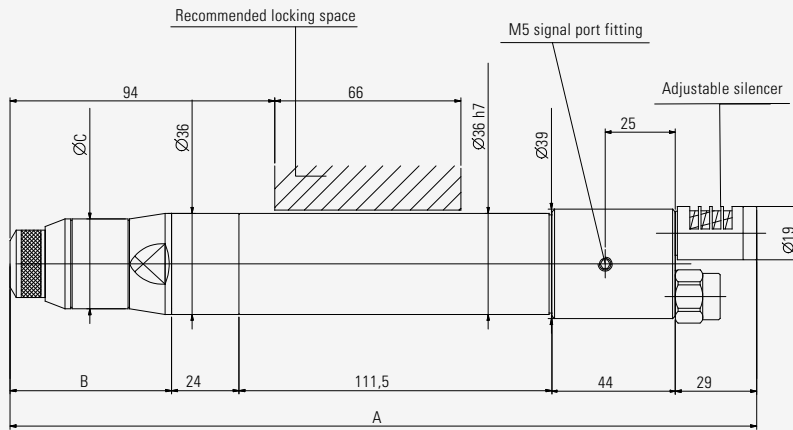

Air exhaust silencer

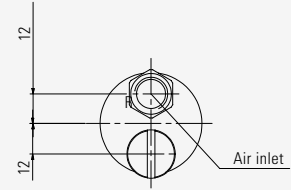

Air exhaust silencer

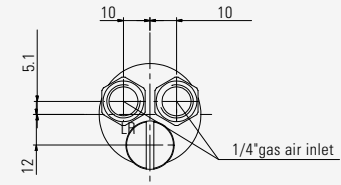

**MCSEZ...A/MCSEZ...RA,
MCSE...A/MCSE...RA,
MSCSEZ...A,
MSCSE...A
MODELS WITH AXIAL COMPENSATOR**

Models	A mm	A1 mm	B mm	Ø C mm
MCSEZ 4 A / MCSEZ 4 RA	394,2	403,5	38	27
MCSE...A / MCSE...RA	401,2	410,5	45	32

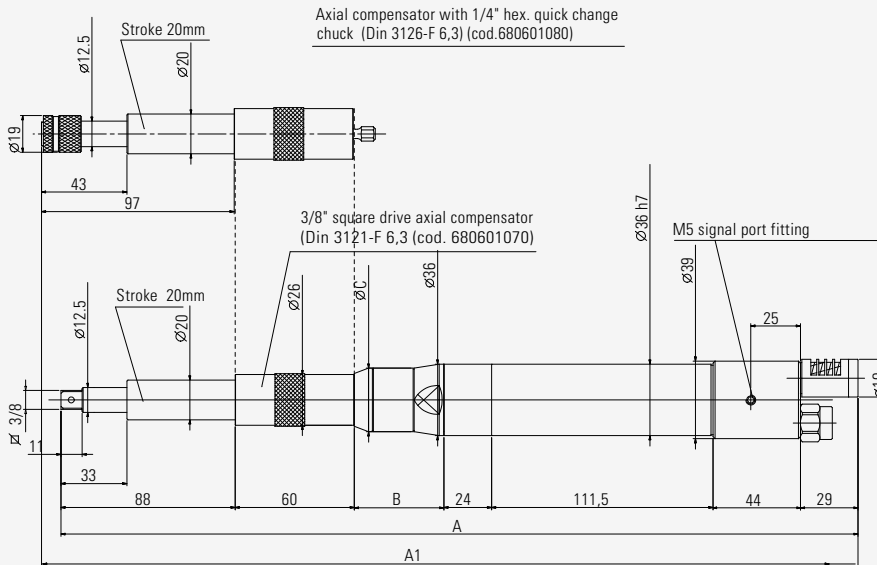

Air exhaust silencer

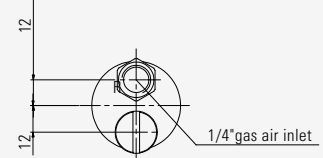

Air exhaust silencer

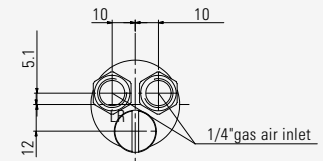

Dimensions

Nutranner motors with air shut-off

MCY9-11A/MCY9-11RA/MSCY9-11A MODELS

Models	A mm	B mm
MCY 9 A / MCY 11 A	315,5	46
MCY 9 RA / MCY 11 RA	330,5	61
MSCY 9 A / MSCY 11 A	318	46

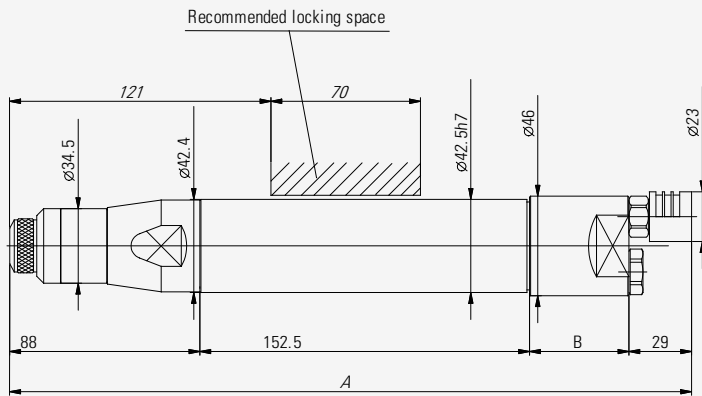

Air exhaust silencer

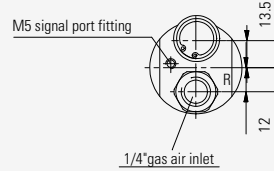

Air exhaust silencer

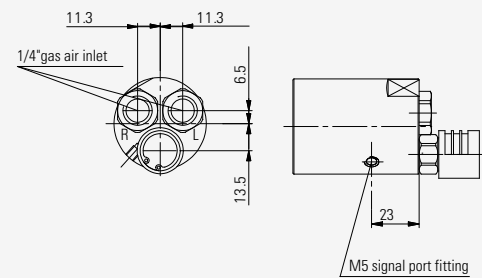

MCY9-11A/MCY9-11RA MODELS WITH AXIAL COMPENSATOR

Models	A mm	A1 mm	B mm	Ø C mm
MCY 9 A / MCY 11 A	448,5	458,3	46	75,5
MCY 9 RA / MCY 11 RA	463,5	473,3	61	75,5

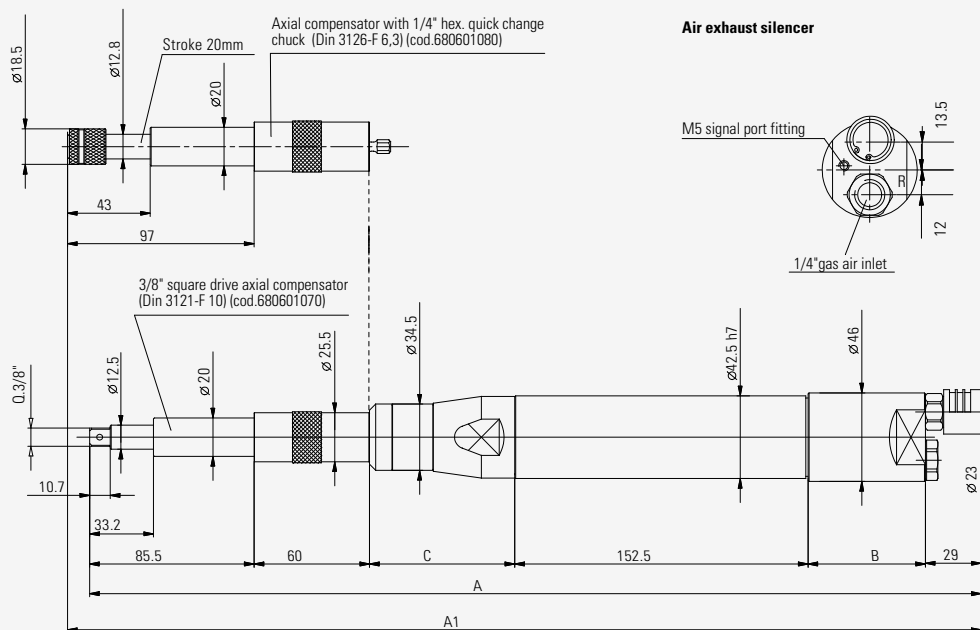

Air exhaust silencer

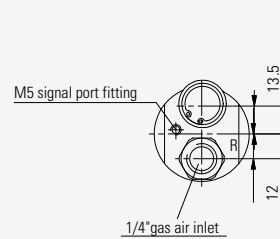

Air exhaust silencer

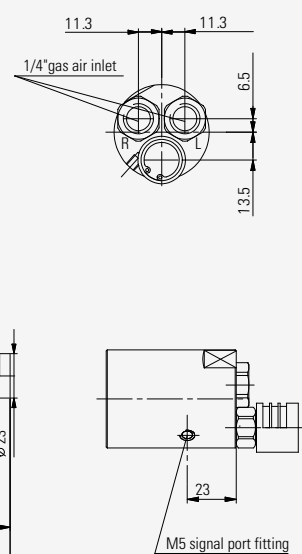

Dimensions

Nutranner motors with air shut-off

MCG...A/MCG...RA MODELS

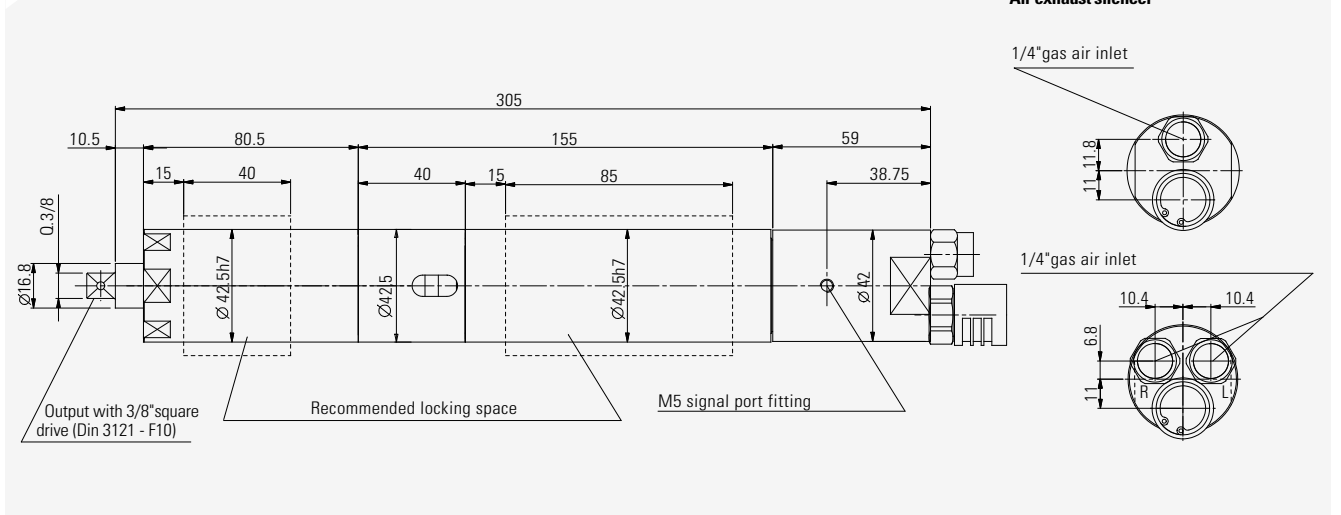

MCG...A/MCG...RA MODELS WITH AXIAL COMPENSATOR

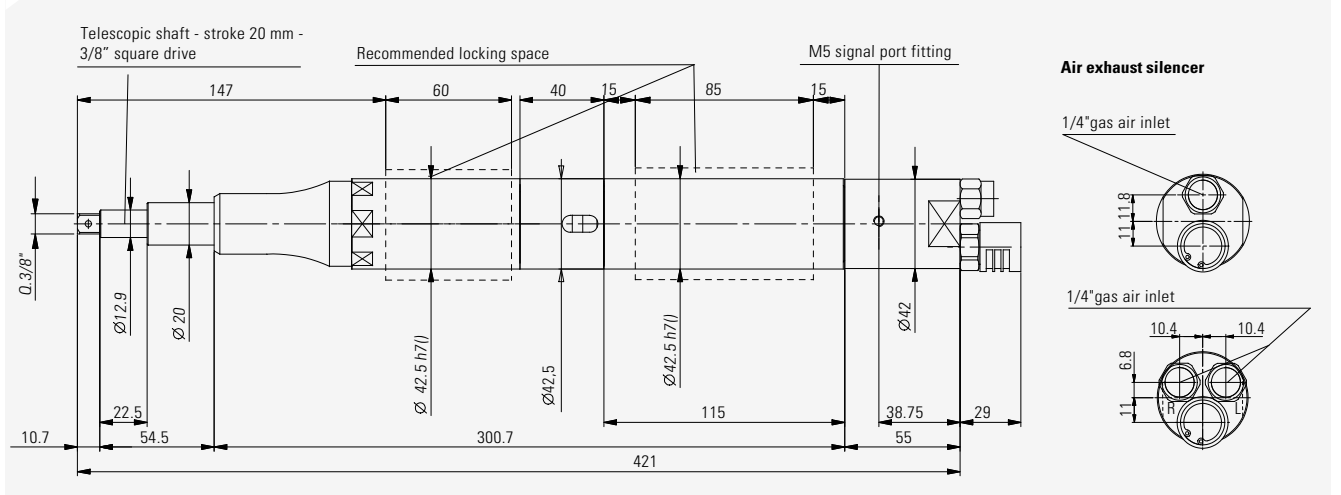

Dimensions

Nutrunner motors with slip clutch

MCZE.../MCZE...R/MSCZE... MODELS

Models	A mm	B mm	Ø C mm
MCZE.../ MCZE...R	211	56,8	30
MSCZE...	232,5	70,5	34

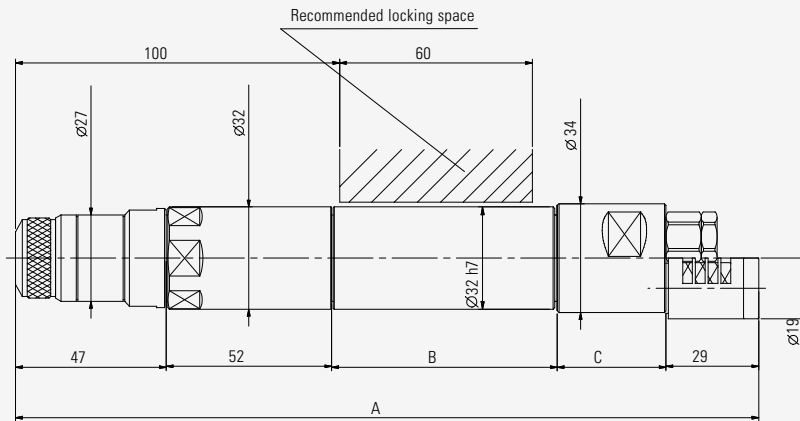

Adjustable silencer

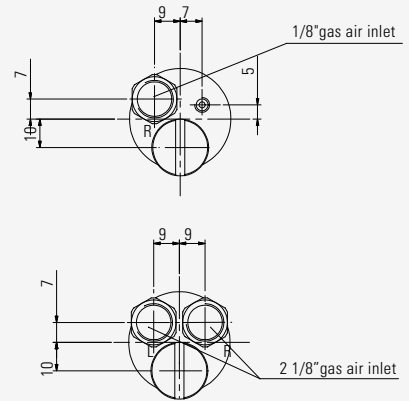

MCZE.../MCZE...R MODELS WITH AXIAL COMPENSATOR

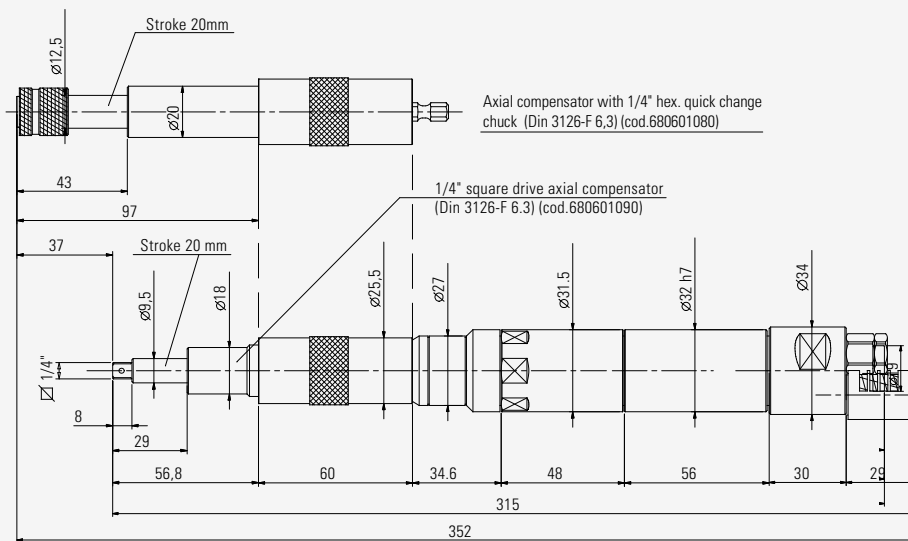

Adjustable silencer

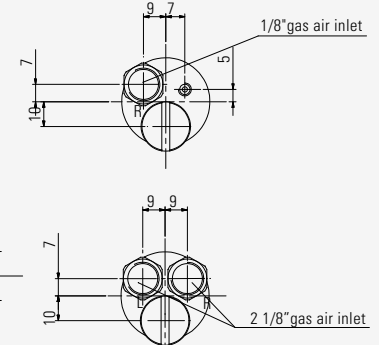

Dimensions

Nutrunner motors with slip clutch

MCSE.../MCSE...R/MSCSE... MODELS

Models	A mm	B mm	Ø C mm
MCSE.../MCSE...R	239	43	32
MSCSE...	253	44,5	44

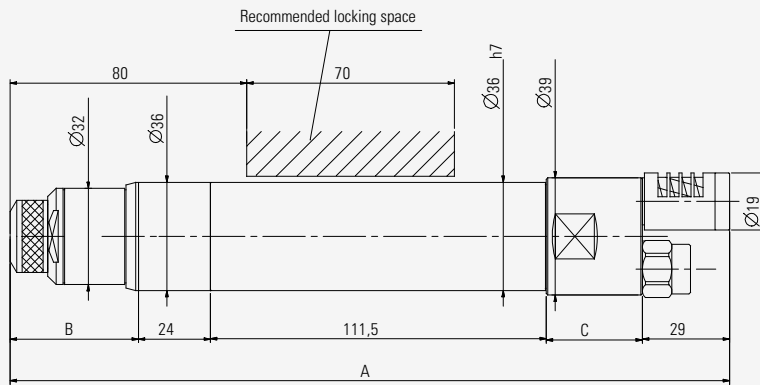

Adjustable silencer

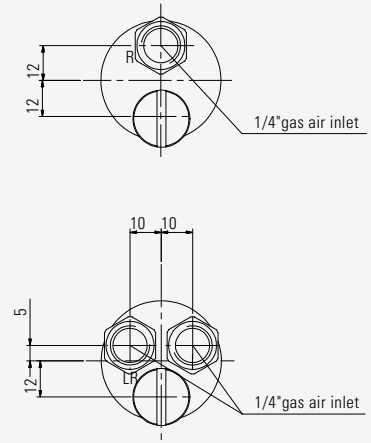

MCSE.../MCSE...R MODELS WITH AXIAL COMPENSATOR

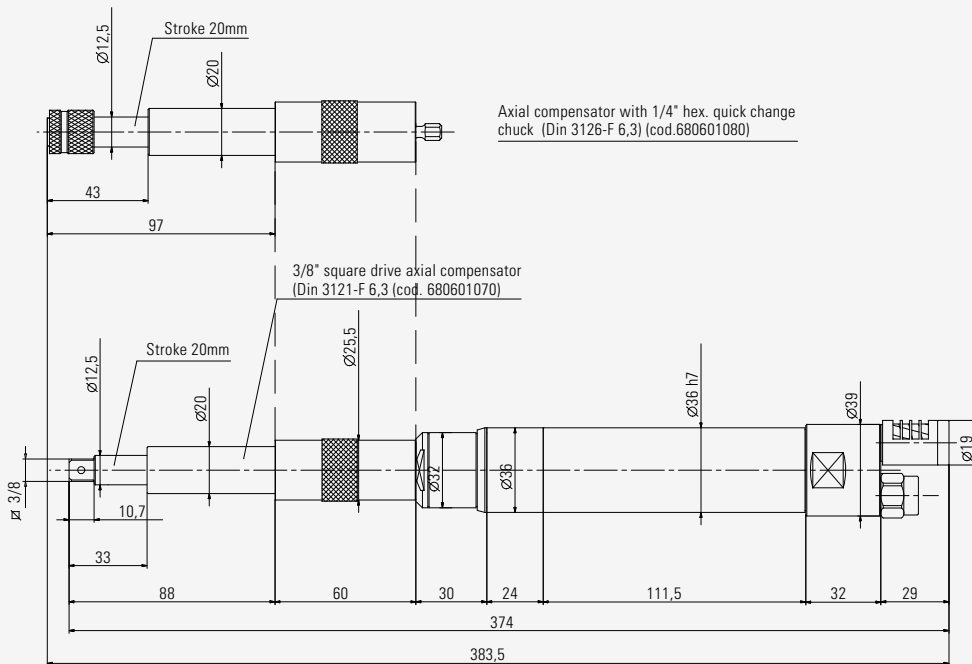

Axial compensator with 1/4" hex. quick change chuck (Din 3126-F 6,3) (cod.680601080)

3/8" square drive axial compensator (Din 3121-F 6,3) (cod. 680601070)

Adjustable silencer

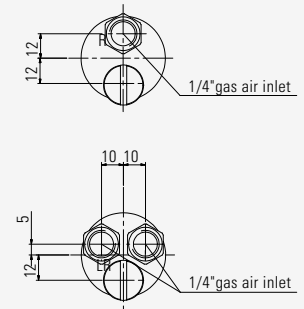

Dimensions

Nutrunner motors with slip clutch

MCY...-1 / MCY...-R1 MODELS

Models	A mm	B mm	Ø C mm
MCY 7-1	255,7	122,5	46
MCY 9 / 11-1	285,7	152,5	46
MCY 7-R1	270,1	122,5	61
MCY 9 / 11-R1	300,7	152,5	61

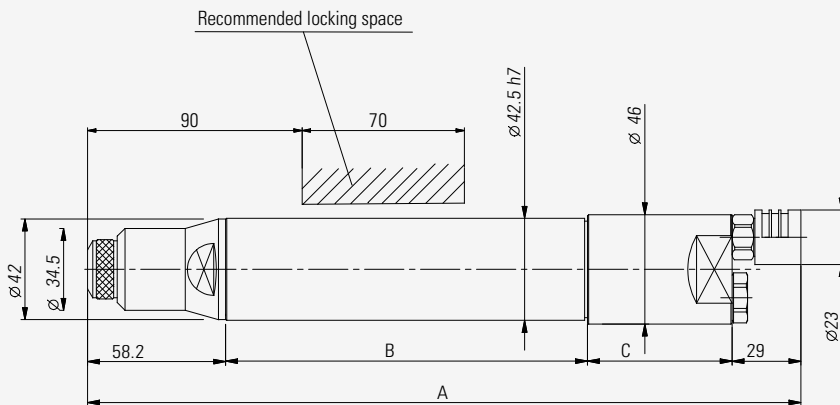

Adjustable silencer

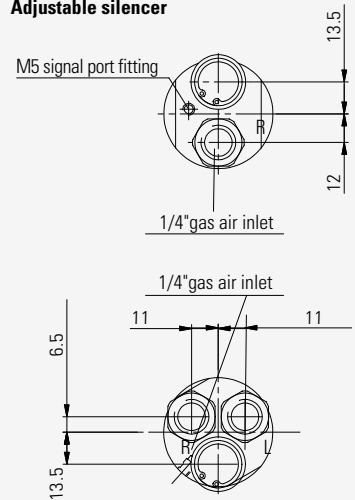

MCY...-1 / MCY...-R1 MODELS WITH AXIAL COMPENSATOR

Models	A mm	A1 mm	B mm	Ø C mm
MCY 7-1	388,7	398,7	122,5	46
MCY 9 / 11-1	418,7	428,7	152,5	46
MCY 7-R1	403,7	413,7	122,5	61
MCY 9 / 11-R1	433,7	443,7	152,5	61

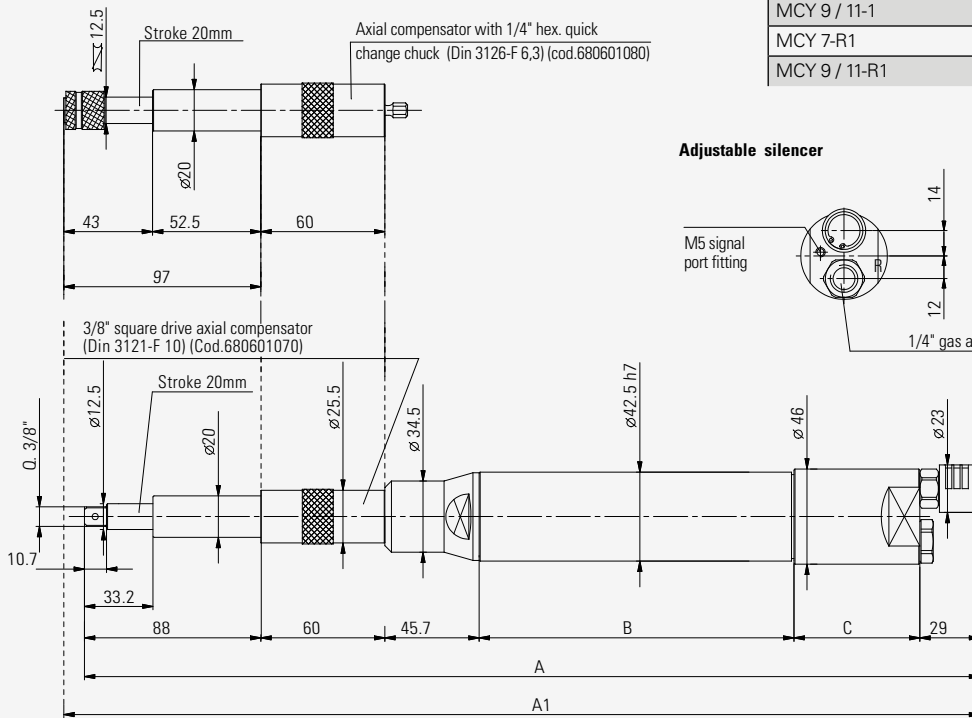

Adjustable silencer

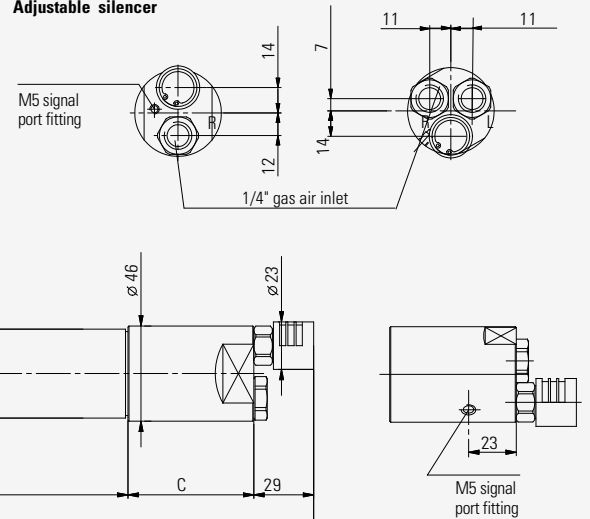

Accessories

AXIAL COMPENSATORS

Ease entry of screw and reduce axial thrust on the motor's mechanical components. When fastening more screws simultaneously, the axial compensation device in the bit compensates for the differences in height between the screws before starting tightening process.

These bits **feature guide bush designed to ensure that compensation bit is centred correctly on nutrunner**. The bit can be used in conjunction with the accessories illustrated in the Accessories Catalogue, fitting a specific adapter between the bit and accessory if required. The spring load of the axial compensation bits is about 3,5 Kg when fully compressed. To use axial compensators on air nutrunner motors with push start please apply to **Fiam Technical Consultancy Service**.

The dimensions of the air nutrunner motors with axial compensation are those reported on page 12 and 18.

□ 1/4" drive axial compensation bit (DIN 3121 - F 6,3)

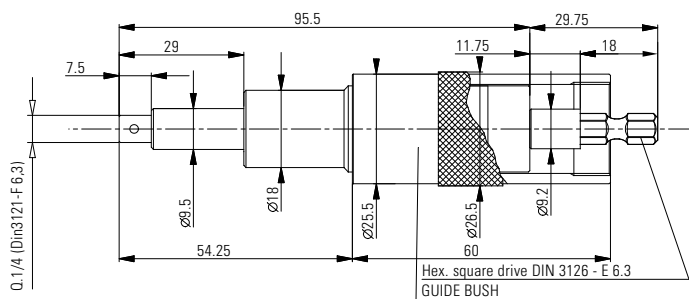

Features	Code	Axial compensator (mm)
For all nutrunner motors	680601090	20

□ 3/8" drive axial compensation bits (DIN 3121 - F 10)

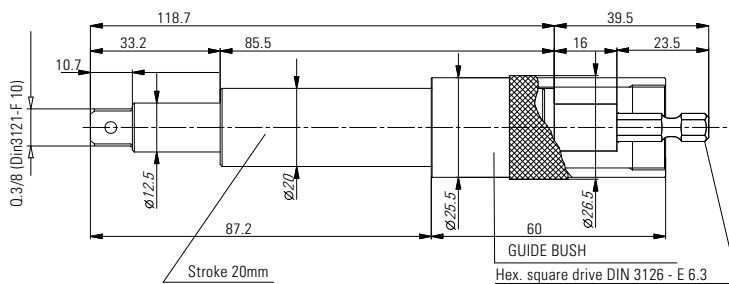

Features	Code	Axial compensator (mm)
For all nutrunner motors	680601070	20

Axial compensation bits with 1/4" quick change chuck (DIN 3126 - F 6,3)

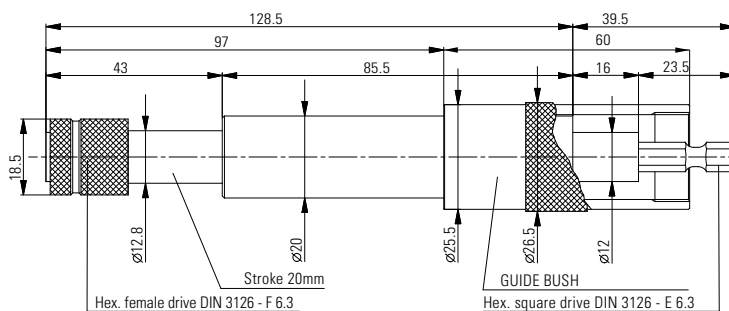

Features	Code	Axial compensator (mm)
For all nutrunner motors	680601080	20

FLANGE BRACKET

We recommend using the 3 hole flange bracket to install a nutrunner motor for screwdriving applications on a fixed mounting, since it acts on the entire circumference of the motor casing, avoiding the possibility of any operating problems.

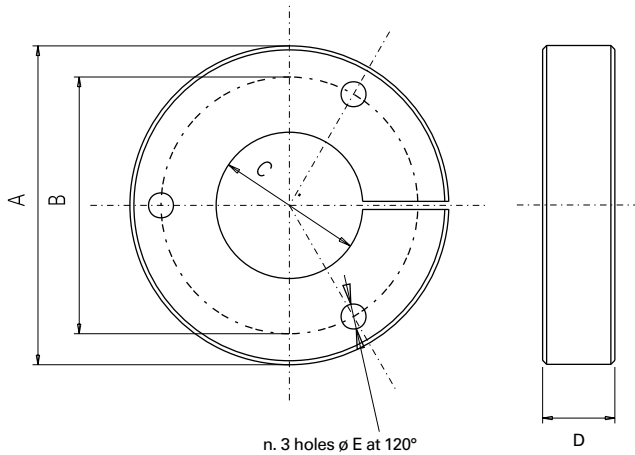

Model	Code	A mm	B mm	C mm	D mm	E mm
20MC...A / 20MC...RA 20MSC...A	684011006	64,5	50	32	18	5,25
MCZE... / MCZE...R MSCZE...						
MCSEZ...A MCSE...A / MCSE...RA MSCSEZ...A MSCSE...A	684011007	69,5	57	36	18	6,25
MCSE... / MCSE...RA MSCSE...						
MCY...A / MCY...RA MCG...A / MCG...RA MSCY...A	684011008	79,5	64	42,5	18	6,25
MCY...-1 / MCY...R-1						

Instructions for installation.

Instruction manual supplied with the nutrunner also gives recommendations about:

- Signal that can be received
- Securing the nutrunner motors
- Adjusting the tightening torque
- Accessory replacement

AIR FEED

To obtain the performances on catalogue it is necessary to guarantee a correct air feeding.

To check whether the nutrunner is being correctly fed, insert a pressure gauge at the air inlet coupling and measure the air pressure with the motor running: it must be about 6 bar. Always respect the air passage recommended by Fiam for feeding hoses.

If possible, avoid joints and quick couplings which locally reduce the air passage.

Connect the exhaust hoses to **oil separator filter with built-in silencing system** that **further reduces the noise** level and **lubricates the motor** with no emission of air exhaust in working environment, allowing oil to be collected and reused. To convey the air exhaust of more motors follow the instructions below.

Scheme for correct feeding of nutrunner motors

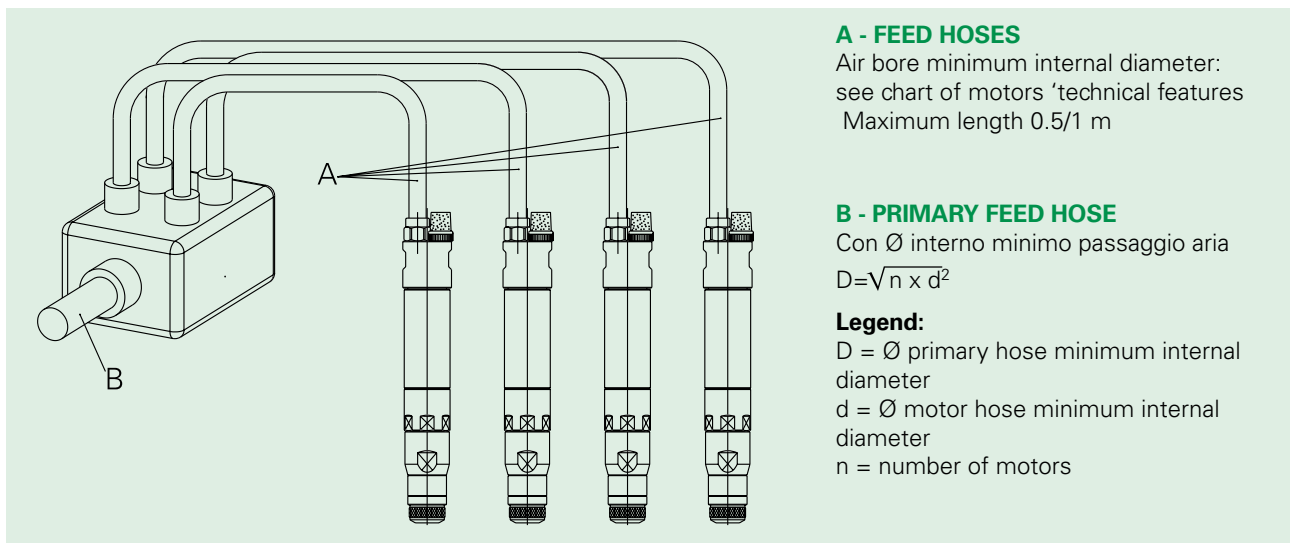

For further information please contact **Fiam Technical Consultancy Service**.

Solutions for industrial tightening automation.

All Fiam air nutrunner motors can be installed on MCA tightening modules with automatic screw feed in order to make working cycles very fast and effective.

They are extremely versatile and can be integrated into existent production systems such as assembly lines, manipulators, electric Cartesian axes, robots and collaborative robots, and the PLC installed in them ensures the performance required for Industry 4.0 environments with automatic process control and management.

MCA tightening modules can be configured for numerous solutions, all entirely designed and manufactured by Fiam for any application sector and any level of complexity. You can count on a solid, sure base: know-how built up over 70 years of specialist knowledge in the industrial tightening field.



Embedded screw passage sensor

controls also very small screws and it isn't influenced by other sensors

Comfortable and rational hose

that includes the air and electric cables between slide and feeder

Pneumatic cylinders

equipped with built-in air decelerators

Fastening slide available in three versions

Air or electric nutrunner motor

Feeder

Screw-retaining heads

MCA TIGHTENING MODULE

For further information about Fiam MCA tightening modules refer to the corresponding catalogue:

- n° 73 Tightening module to be integrated into automatic production system

1

EasyDriver screw feeding

They manage the entire working cycle with great flexibility because they manage the tightening sequences quickly and easily, customising them to the specific applications. The **INTEGRATED PLC** manages all machine parameters according to the tightening needs.

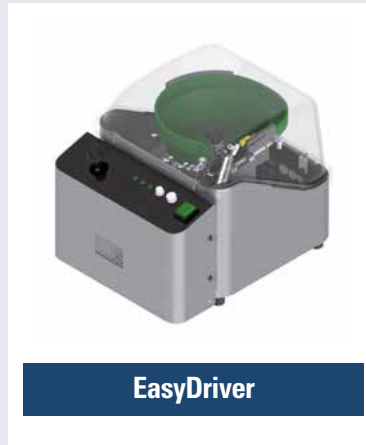

2

Fastening slides

They ensure a **precise approach stroke of the nutrunner motor/ screw-retaining head to the component**, guaranteeing **high reliability of the assembled product** since all screws are tightened with great precision. Made from aluminium alloy, they are light and compact (only 40 mm in width) and can be **used on manipulators, electric axes or robots**. They can also withstand substantial axial thrust (e.g. assembly with self-drilling screws).

Devices for Cobots

Fiam tightening modules are designed to be used with collaborative robots, too, by using a **special (patented) auto-advance device** that performs the tightening strokes.



SL15 model
• Min. centre-to-centre distance 41 mm

SL20 model
• Min. centre-to-centre distance 51 mm

SL15 model
• Min. centre-to-centre distance 41 mm

3

Nutrunner motors: air or DC-driven

Specifically designed and manufactured for **industrial automation, they meet every need in terms of tightening accuracy**. Extremely sturdy, Fiam nutrunner motors guarantee constant performance for all torque requirements, even when used in heavy duty conditions.

Different torque control systems are available for different applications and types of joint and screw.



0,4 ÷ 40 Nm

- they ensure high performance even at low air feed pressure
- air-shut off models



EasyDriver Maxi 1|1



EasyDriver 2|1



EasyDriver 1|2

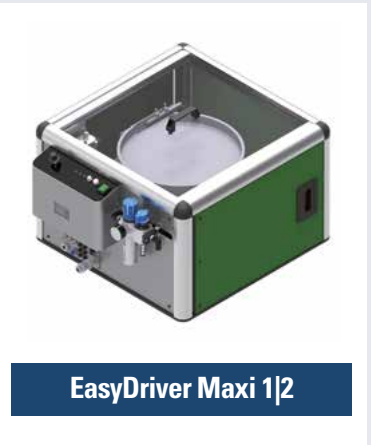

EasyDriver Maxi 1|2



AL-STROKE FASTENING SLIDE

SL20 model
• Min. centre-to-centre distance 51 mm



TRIPLE-STROKE FASTENING SLIDE

SL15 model
• Min. centre-to-centre distance 41 mm



TIGHTENING MODULE FOR COBOTS

0,1 ÷ 5, 6 Nm

- The device is designed to be fixed to the Cobot's wrist with a bracket and can communicate with the PLC



DC DRIVEN NUTRUNNER MOTOR

up to 50 Nm

- for the control, monitoring and systematic checking of the whole assembly process and data logging and statistics
- models with:
INDIRECT CONTROL
(based on current absorption)
or
DIRECT CONTROL
of the tightening torque/angle



TOD

TOC



TCS - B E



CT2500A

**To choose your
tightening
solutions,
read the
following
catalogues
online**

**Components
for tightening
automation**



MCA
Tightening module to be
integrated into automatic
production systems



**High-tech automatic
tightening solutions**

www.fiamgroup.com

July 2019 - 90 | Printed on recycled paper for the safeguard of the environment | Copyright Fiam Spa. The unauthorised distribution and/or reproduction of all or part of this publication is strictly forbidden.